

**MYNYDD MAEN
WIND FARM**

FIGURE 3.5

**ACCESS TRACK
TYPICAL DETAILS**

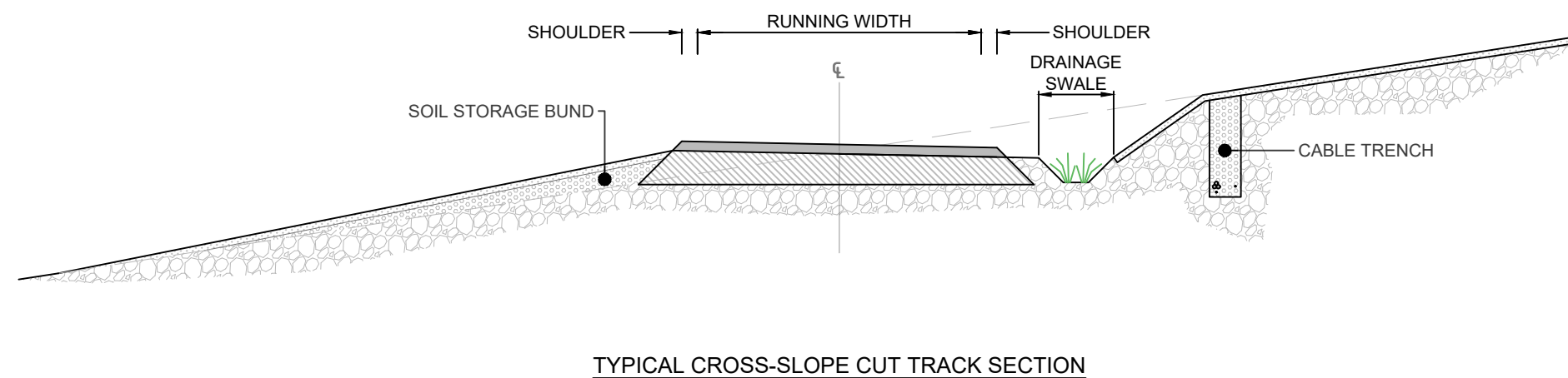
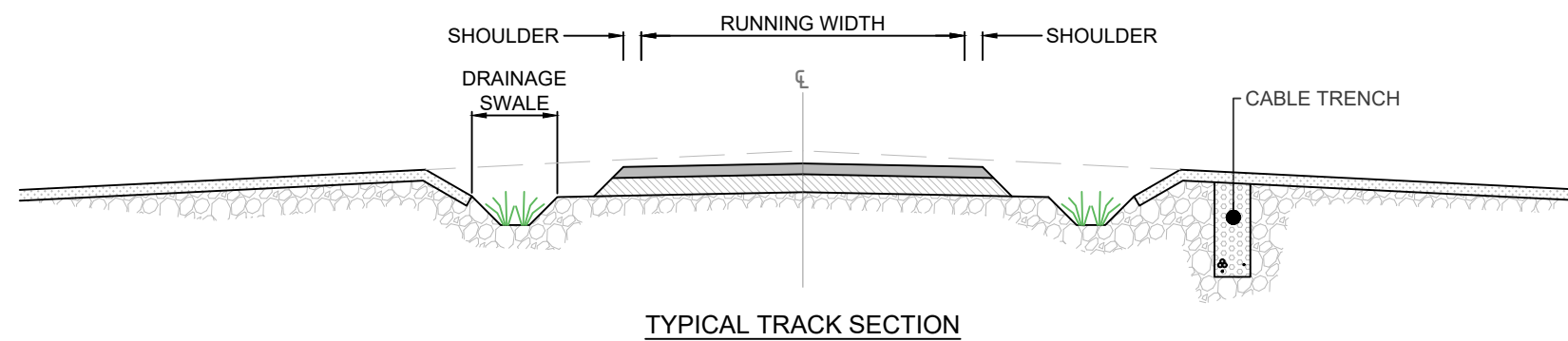

KEY:

- RUNNING SURFACE
- BASE / CAPPING LAYER
- TOPSOIL
- SUBGRADE
- EXISTING GROUND LEVEL

NOTES:

1. DO NOT SCALE FROM THIS DRAWING.
2. TRACK WIDTH TO INCREASE ON BENDS AND PASSING PLACES.
3. ALL EMBANKMENT SLOPES TO BE PROVIDED AT A STABLE ANGLE BASED ON THE PROPERTIES OF THE MATERIAL ENCOUNTERED ON SITE.
4. TRACK CONSTRUCTION TYPE TO BE DETERMINED DURING DETAILED DESIGN. LAYOUT OF DRAINAGE, CABLE TRENCHES AND STORAGE BUNDS MAY VARY.
5. RUNNING SURFACE AND BASE/CAPPING LAYER TO BE FORMED FROM SUITABLE MATERIALS COMPACTED IN LAYERS.
6. GEOSYNTHETIC REINFORCEMENT OR SOIL STABILISATION MAY BE USED TO REDUCE THE DEPTH OF TRACK CONSTRUCTION. REQUIREMENT TO BE DETERMINED DURING DETAILED DESIGN.

LAYOUT DWG	N/A	T-LAYOUT NO.	N/A
------------	-----	--------------	-----

DRAWING NUMBER	04412-RES-ACC-DR-PE-006	REV	3
----------------	-------------------------	-----	---

SCALE - NOT TO SCALE

**ENVIRONMENTAL STATEMENT
2024**

THIS DRAWING IS THE PROPERTY OF RENEWABLE ENERGY SYSTEMS LTD. AND NO REPRODUCTION MAY BE MADE IN WHOLE OR IN PART WITHOUT PERMISSION